

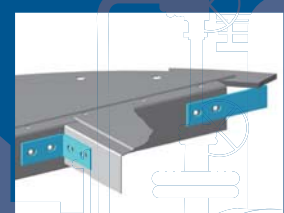

TRAY TECHNOLOGY

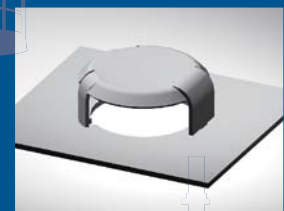
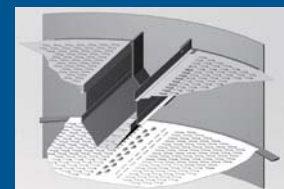
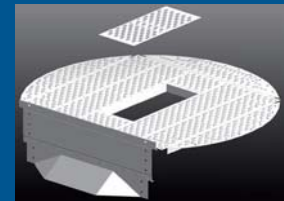

INNOVATIVE SOLUTIONS **RELIABLE PERFORMANCE**

CONTENTS

GTI Solutions Capabilities	Page 1
Valve Tray Product Portfolio	Page 2
Movable Valve Tray Technology	
Fixed Valve Tray Technology	
G-HPT™ Technology	Page 5
G-Frac™ High Performance Trays	
G-MxPush™ High Performance Trays	
G-MxMD™ High Performance Trays	
G-AFT™ Anti Fouling Technology	
Other Conventional Trays.....	Page 9
Sieve Trays	
Bubble Cap Trays	
Dual Flow Trays	
Baffle Trays	
Liquid-Liquid Extraction Trays	Page 10
Liquid-Liquid Extraction Sieve Trays	
G-EXT™ Extraction Trays	
Tray Design Consideration	Page 11
Uplift Resistance Tray Design	
Quick-Lock™ Construction	

Your Partner in Distillation Technology

GTI SOLUTIONS is a process equipment and technology company committed to providing innovative mass transfer equipment and solutions to the refining, chemical and petrochemical industries.

Customer satisfaction is our top priority. We work to earn each client's trust and loyalty by providing customized solutions to all their process engineering needs with rapid response time and competitive pricing.

Our process design engineers have extensive experience in a wide range of mass transfer applications and work closely with each client to deliver measurable results that maximize production performance and unit profitability.

Our portfolio of products and services includes:

- Conventional trays
- High Performance trays
- Random packing
- Structured packing
- Grid packing
- Column internals
- Mist eliminators
- Liquid-liquid coalescers
- Reactor internals
- Divided wall column technology
- Process validation
- Performance test runs
- CFD modeling
- Engineering services
- Feasibility and complex revamp studies
- Expedited replacement services
- Troubleshooting services
- Technical training
- Site supervision services

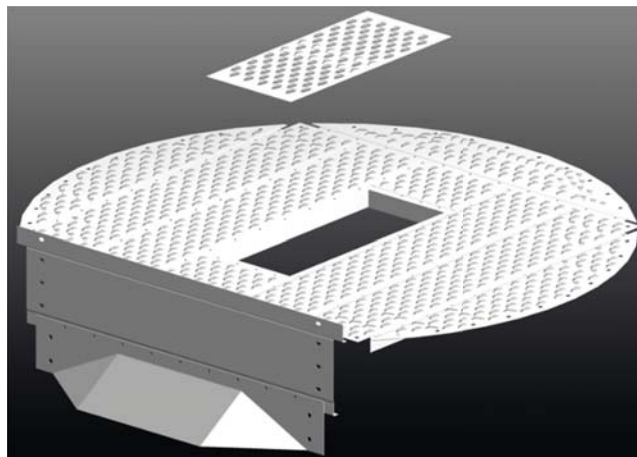

Our mass transfer equipment is designed to operate in a range of applications and can be fabricated in a variety of corrosion resistant materials such as zirconium, titanium, monel, duplex steels, stainless steel, and other exotic alloys.

Valve Tray Product Portfolio

Valve trays have been the industry standard for more than five decades and continue to dominate the market for the majority of applications.

Valve trays provide the important advantage of higher capacity, higher efficiency, good fouling resistance, and lower pressure drop compared to bubble cap trays.

Valve trays feature a lateral release of vapor, leading to lower entrainment, higher capacity and a wider operating range compared to sieve trays.



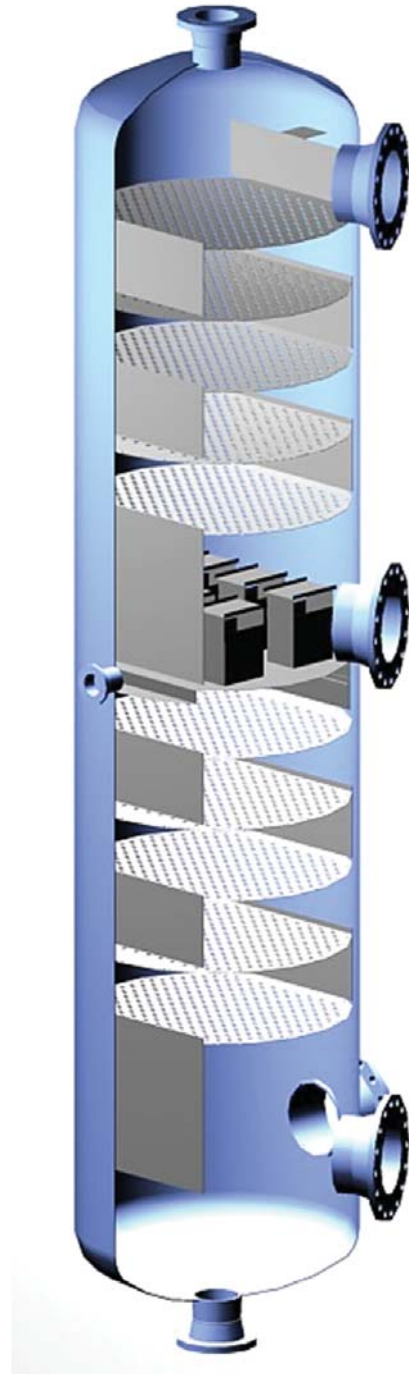

GTI SOLUTIONS offers more than 10 different types of valves including:

- Round valves
- Caged valves
- Miniature movable valves
- Standard rectangular valves
- Miniature fixed valves

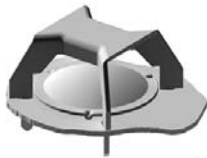
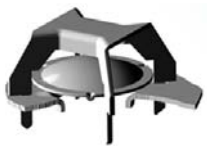

From low pressure refinery fractionators to high pressure columns and superfractionators, GTI Solutions engineers can fully customize each tray design to provide higher capacity, lower pressure drop and better separation performance.



Movable Valve Tray Technology

Product	Type	Features	Performance
<p>G-V1™</p> 	<p>One-piece industry standard round valve with standard flat orifices located on the tray deck</p>	<p>1-2 mm tabs prevent valves from adhering to the tray deck</p> <p>Flush seated valves available for clean services</p> <p>Different leg lengths available to accommodate tray floor thicknesses</p> <p>Anti-spin deck orifice design</p>	<p>Higher capacity compared to sieve trays</p> <p>Typical operating range of 3:1</p> <p>Higher operating range possible with multi-weight valves</p>
<p>G-C1™</p> 	<p>Two-piece cage valve with the cage fixed to the tray deck and a moving valve disc with flat orifices located on the tray deck</p>	<p>Robust design and difficult to dislodge from the tray deck</p> <p>1-2 mm tabs prevent valves from adhering to the tray deck</p> <p>Flush seated valves available for clean services</p> <p>Different leg lengths available to accommodate varying tray thicknesses</p>	<p>Typical operating range of 4:1</p> <p>Same capacity as G-V1 valves with a slightly lower pressure drop and lower weeping tendency</p>
<p>G-C4™</p> 	<p>Two-piece cage valve with the cage fixed to the tray deck and a moving valve disc with venturi orifices located on the tray deck</p>	<p>1-2 mm tabs prevent valves from adhering to the tray deck</p> <p>Flush seated valves available for clean services</p> <p>Different leg lengths available to accommodate varying tray thicknesses</p>	<p>Typical operating range of 4:1</p> <p>Same capacity as G-V1 but provide the lowest pressure drop when compared to all other movable valve types</p>
<p>G-mV1™</p> 	<p>Miniature movable valve with anti-spin construction</p>	<p>1-2 mm tabs prevent valves from adhering to the tray deck</p> <p>Proprietary shape promotes liquid plug flow on the tray deck while maintaining uniform distribution</p>	<p>Higher operating range when compared to fixed valve trays</p> <p>Higher capacity and superior performance compared to conventional valves due to lower entrainment and even froth height</p>
<p>G-BD1™</p> 	<p>One-piece standard rectangular valve</p> <p>* Available upon request or as a replacement to other OEM suppliers</p>	<p>Different leg lengths available to accommodate varying tray thicknesses</p>	<p>Capacity, operating range and pressure drop are similar to G-V1 valves</p>
<p>G-V4™</p> 	<p>One-piece industry standard round valve with venturi orifices located on the tray deck</p> <p>* Available upon request or as a replacement to other OEM suppliers</p>	<p>1-2 mm tabs prevent valves from adhering to the tray deck</p> <p>Different leg lengths available to accommodate varying tray thicknesses</p>	<p>Capacity, operating range and pressure drop are similar to G-V1 valves</p>

Fixed Valve Tray Technology

Product	Type	Features	Performance
<p>G-mF1™</p> 	<p>Miniature fixed valve and integral to the tray deck</p>	<p>Eliminates liquid gradient on the tray deck and lowers froth height</p> <p>Provides optimum liquid distribution resulting in greater fouling resistance</p> <p>Net rise can be varied depending on the tray deck thickness and application</p> <p>No moving parts, eliminating wear or erosion</p>	<p>Typical operating range of 2.5:1</p> <p>Higher operating range possible with a slight increase in pressure drop</p> <p>Higher capacity and better performance compared to conventional valve trays</p>
<p>G-pF1™</p> 	<p>Miniature fixed valve punched out of the tray deck</p>	<p>Self-cleaning action on the tray deck minimizes the accumulation of fouling material</p> <p>Eliminates stagnant liquid zones by promoting uniform liquid flow on the tray deck</p> <p>Provides directional vapor release</p>	<p>Low fouling risk due to the uniform residence time on the tray deck</p> <p>Eliminated liquid gradient and even froth height provide higher capacity and superior performance compared to conventional valve trays</p>
<p>G-sF2™</p>  <p>(patent pending)</p>	<p>Industry standard fixed valve with a separate unit fixed onto the tray deck</p>	<p>Promotes liquid distribution, self-cleaning action and the highest net rise to achieve high fouling resistance</p>	<p>Lower liquid gradient, reduced entrainment and even froth height provide higher capacity and better performance</p> <p>Higher operating range compared to other fixed valve trays</p>

G-HPT™ Technology

The inherent valve layout of conventional trays often causes unequal liquid distribution and froth height across the tray deck. This limits the trays ability to fully utilize the area available within a given diameter resulting in reduced tray capacity and efficiency.

G-HPT trays is a high performance tray that eliminates the inherent problems encountered with conventional trays through active / inlet area enhancements and improved downcomer designs. As a result, G-HPT trays can deliver the following benefits:

- Minimized inactive zones
- Balanced hydraulic (liquid) gradient
- Increased active bubbling area
- Reduced back mixing
- Reduced tray pressure drop
- Longer flow path length
- Uniform froth height across the entire active area
- Improved separation performance
- Wider operating range
- Reduced entrainment
- Higher capacity

Tray deck enhancement

- Active Area Improvement

G-HPT trays feature miniature valves such as G-mF1, or G-mV1 along with directional valves such as G-pF1, which are arranged in a predetermined pattern on the active area of the tray deck.

The small valve size and proprietary shape lowers the entrainment while the predetermined arrangement of the directional valves eliminates stagnant liquid zones. These features create a uniform froth height across the tray deck resulting in higher capacity, improved performance and better fouling resistance.

- Inlet Area Improvement

The inlet area of G-HPT trays comes equipped with froth initiators and/or directional devices to ensure the liquid exiting the downcomer is aerated immediately and uniformly distributed across the entire cross sectional area of the tray.

These features along with active area improvements eliminate the liquid gradient and back mixing, improving tray capacity and efficiency.

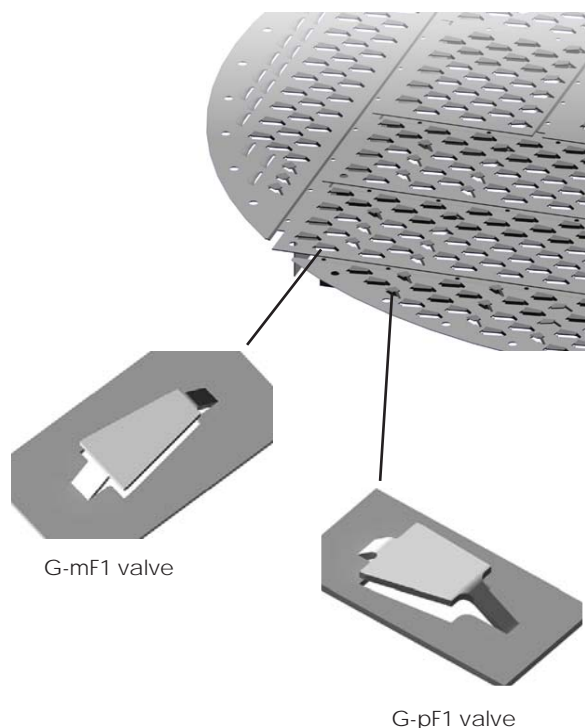

Improved Downcomer Technologies

G-HPT tray can be equipped with a wide variety of downcomers such as multi-chordal, truncated or multi-pass downcomers.

The proprietary downcomer shapes increase the active area, improve the downcomer liquid carrying capacity and maximize the flow path length.

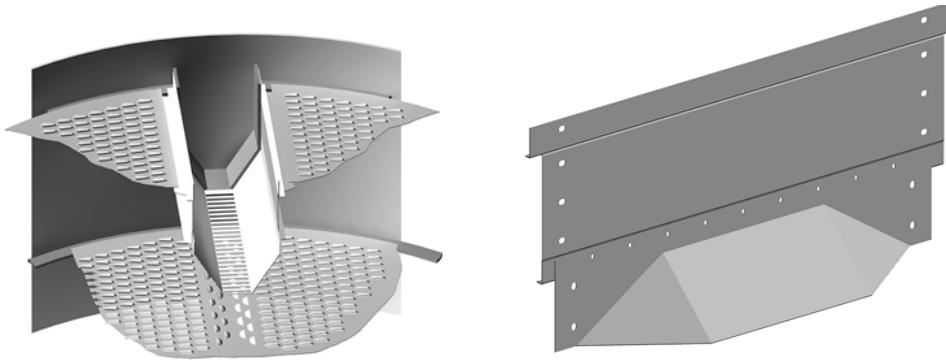

Truncated Downcomer

Multi-Chordal Downcomer

When compared to conventional trays, G-HPT in general provides 20% ~ 30% higher capacity while maintaining the same or higher efficiency.

G-HPT technology is especially well suited for column revamps and can be safely, quickly, and easily installed leading to shorter turnaround times. G-HPT is also well suited for new tower construction and can reduce column diameter and/or lower tray spacing, lowering capital costs.

G-HPT technology can be used in a wide variety of applications ranging from low to high pressure fractionators. Some typical applications include:

- Superfractionators such as a C3 splitter, C2 splitter or deisobutanizer
- Aromatics units
- High pressure fractionators such as a demethanizer, deethanizer, depropanizer or debutanizer
- Dehydration and HP Absorber columns within PTA units
- Refinery main fractionators such as a crude column, FCC or hydrocracker main fractionator
- Petrochemical units such as a AN, VAM, VCM, EO/EG, EDC, acetone, ECH, butadiene, and isoprene applications

G-HPT technology provides mainly four different types of trays to suit individual applications namely:

- G-Frac™ high performance trays
- G-MxFrac™ high performance trays
- G-MxMD™ high performance trays
- G-AFT™ anti fouling trays

G-Frac™ High Performance Trays

G-Frac trays use tray deck enhancements and improved downcomer technology to achieve higher capacity while maintaining or improving efficiency. G-Frac tray construction features include:

- Column diameter \geq 800 mm
- Use of miniature valve technology on the tray deck (G-mF1 or G-mV1)
- Application of push valves G-pF1 and inlet flow promoters
- Use of multi-chordal or truncated downcomer design to maximize active area
- Use of Quick-Lock™ construction for easy assembly and reduced installation time (bolted construction available upon request)

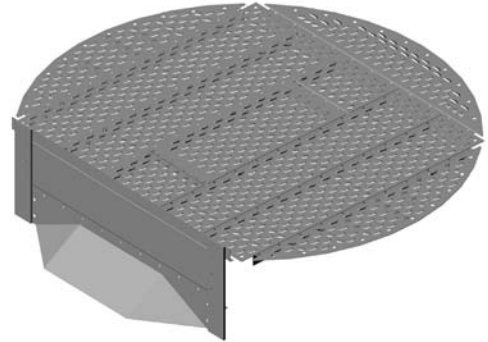

G-Frac trays can also include other custom features such as a de-entrainment device below the tray deck to handle high vapor loads when combined with low liquid applications. In addition, for revamp applications, existing tower attachments can be reused to minimize field modifications and avoid hot work inside the column, resulting in quicker plant turnaround.

G-MxPush™ High Performance Trays

Conventional trays in pump-around and other high liquid load applications are prone to excessive liquid gradients and uneven froth heights, limiting tray capacity. G-MxPush trays have been developed specifically to reduce the liquid gradient across the tray deck and provide uniform vapor distribution. G-MxPush construction features include:

- Column diameter \geq 1000 mm
- Use of high performance valve technology on the tray deck (G-pF1 or G-sF2), to encourage momentum in the direction of the liquid flow
- Use of multi-chordal or truncated downcomer design to maximize the active area
- Use of Quick-Lock construction to reduce installation time (bolted construction available upon request)

G-MxMD™ High Performance Trays

G-MxMD trays combine the high performance of G-HPT tray technology along with multi-downcomer designs to maximize tray capacity for any given tray diameter. The tray design retains cross flow technology and also maintains good efficiency. G-MxMD construction features include:

- Column diameter \geq 2000 mm
- A large downcomer area with a long weir length
- Miniature valve technology used on the tray deck (G-mF1 or G-mV1) to maximize vapor capacity
- Use of a multi-downcomer design to reduce clear liquid back-up and weir load, allowing for low tray spacing while maintaining good tray capacity and efficiency

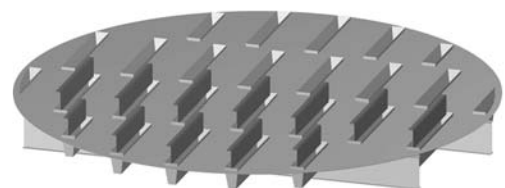

G-AFT™ Anti Fouling Technology

Refining and petrochemical operators are increasingly processing complex feed-stocks making columns more susceptible to fouling. When unwanted material begins to accumulate on the tray surface it increases pressure drop, reduces separation, lowers unit capacity and reduces unit run length. As a result, energy consumption and operational costs increase.

G-AFT anti-fouling tray was designed specifically to counter foulings on the tray deck by eliminating stagnant liquid zones, reducing residence time and providing self-cleaning capability. In addition, mechanical features such as a self-draining integral truss or a sloped outlet weir can be included to minimize fouling above and below the deck floor.

For severe fouling services, our proprietary downcomer design can be used to eliminate the accumulation of fouling material within the downcomers.

G-AFT anti-fouling trays can be used in a variety of applications including:

- HCl and heavy ends columns within VCM units
- Quench columns and primary fractionators in ethylene plants
- Butadiene and isoprene plants
- Recovery, heads and dry columns within AN units
- Stripping sections of crude columns, especially those using heavy crude slates
- Coker fractionators
- PVC slurry strippers
- Sour water strippers



Fouling Systems Continuum for Trays

Although fouling is an inherent process issue and cannot be permanently eliminated, G-AFT trays can substantially delay the onset of problems caused by the accumulation of unwanted material on tray surfaces. As a result, the unit's on-stream time can be increased, significantly reducing the maintenance cost.

When designing trays for fouling applications, it is important to fully understand the fouling mechanisms, the process of fouling and the effects of fouling on the tray operation. This ensures that the most optimum tray is used for each application.

Figure 1 is a general design guideline for selecting trays in fouling applications based strictly on fouling resistance.

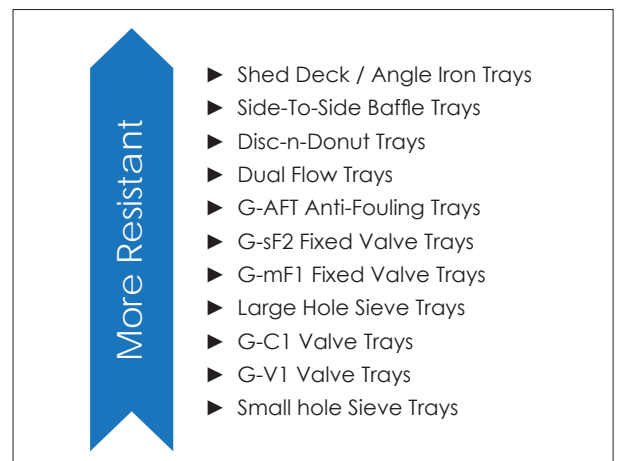

Figure 1

Other Conventional Trays

GTI SOLUTIONS also provides a wide range of conventional trays such as sieve, bubble cap, dual flow and baffle trays to meet clients' needs.

Sieve Trays

Sieve trays are conventional cross flow trays with perforated decks

Typical hole size is 1/2" (13 mm) but can vary from 1/4" (6 mm) to 1" (25 mm)

Typical operating range is 2:1

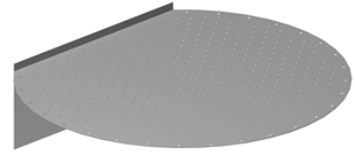

Bubble Cap Trays

Useful where large operating ranges are required such as 10:1 or with very low liquid rates

Cap can be slotted or un-slotted and comes in sizes ranging from 3" (75 mm) to 6" (150 mm)



Dual Flow Trays

Dual Flow Trays are perforated trays that do not have downcomer. Vapor and liquid travel through the same perforations.

Dual Flow Trays have a high open area and high capacity but narrow operating range. The perforations can range from 1/4" (6 mm) for clean services to 1" (25 mm) for fouling applications. These trays are typically used in heat transfer applications or high fouling services.

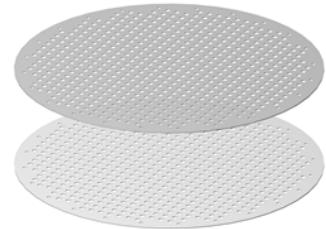

Baffle Trays (Shed-Deck Trays and Disc-n-Donut Trays)

Baffle Trays are equipped with a large open area (30%~50%) and are primarily used in heat transfer applications or severe fouling services where separation efficiency is not important. Contact between liquid and vapor occurs when the vapor passes through the descending curtain of liquid as it flows up the tower.

Shed-Deck trays are multi-pass baffle trays with sloped baffles.

Disc-n-Donut trays are also baffle trays where baffles are shaped in the form of a disc & donut and are arranged in an alternating pattern.

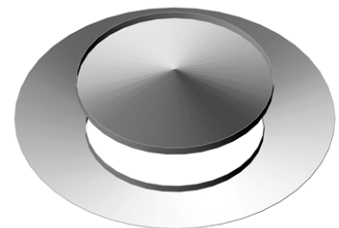
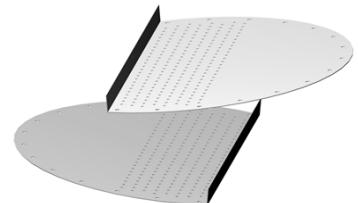

Liquid-Liquid Extraction Trays

GTI SOLUTIONS offers both conventional Liquid-Liquid Extraction (LLE) sieve trays and high performance G-EXT™ Extraction trays.

Typically the liquid with a larger flow rate is dispersed. However, other factors such as wetting characteristics, density gradients and direction of mass transfer must also be taken into consideration.

Tray extractors are typically cheaper than packed columns unless the towers are less than 700 mm, in which case packed columns are more cost effective.

Liquid-Liquid Extraction Sieve Trays

Liquid-liquid extraction sieve trays are the most widely used trays in the industry due to their simplicity, reliability, low cost and ability to handle fouling applications.

LLE Sieve Trays are perforated trays equipped with downcomers or upcomers, based on which phase (heavy or light) is dispersed.

Perforation size can vary from 3 mm (1/8") to 6 mm (1/4") and can be simple flat orifice or extruded holes.

G-EXT™ Extraction Trays

As a column load increases, the use of conventional LLE sieve trays can lead to higher cross-flow velocity, causing a loss of capacity and separation efficiency.

In addition, the use of standard tray construction can cause disturbance in the coalesced layers that can negatively affect tray efficiency.

G-EXT Extraction Trays have been developed to overcome above limitations by use of proprietary mechanical construction and downcomer design to maximize tower performance.

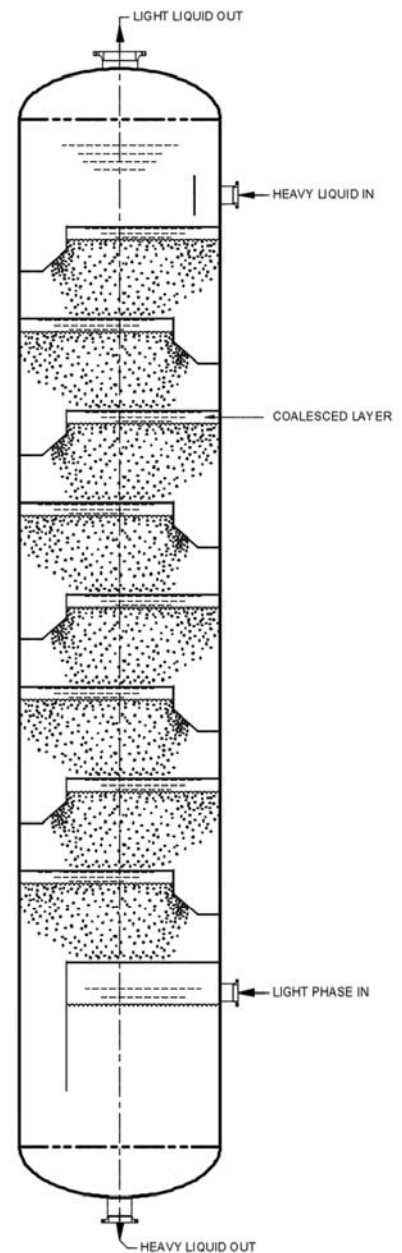

Tray Design Consideration for Trays

Uplift Resistance Tray Design

In severe operating services such as stripping sections in crude columns, trays are prone to mechanical failure caused by operational upsets leading to a loss of separation performance.

As result, GTI SOLUTIONS recommends using uplift resistance trays that offer a reinforced design with an uplift load of 1 psi (700 kg/m²) to 2 psi (1400 kg/m²).

The trays are designed with one or more of the following features

- Reduced bolting pitch
- Through bolted construction
- Double nuts
- Shear clips or stiffeners.

Upon request, explosion hatch/relief doors can be provided on the tray deck to relieve any excess pressure build-up during upsets.

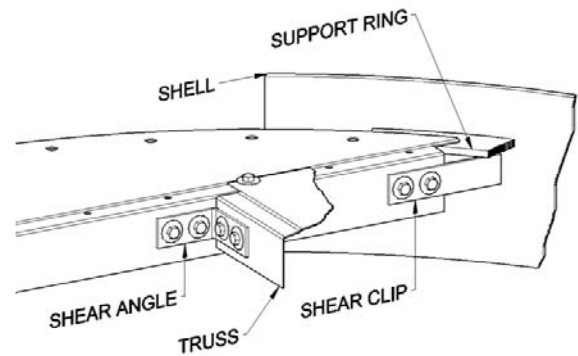

Quick-Lock™ Construction

GTI SOLUTIONS Quick-Lock construction is designed with boltless panel-to-panel connection that not only eliminates hardware requirements for panel to panel joints, but also reduces installation time typically by 20%~30%.

Quick-Lock construction can also improve tray uplift resistance and optimizes valve coverage on the tray active area.

Global Locations

Korea: GTI Solutions Korea Co., Ltd.

Technical & Sales Office

Mapo-gu, Seoul
Phone: +82-2-6246-7400
Fax: +82-2-6246-7409
Email: gtis-korea@gtisoln.com

Manufacturing Facility

Wonju-si, Gangwon-do
Phone: +82-33-901-9241
Fax: +82-33-901-9295
Email: gtis-korea@gtisoln.com

USA: GTI Solutions International LLC.

Technical & Sales Office

Dallas, Texas	Houston, Texas
Phone: +1-707-400-0214	Phone: +1-346-219-3418
Fax: +1-707-202-1916	Fax: +1-707-202-1916
Email: usa@gtisoln.com	Email: usa@gtisoln.com

Japan: GTI Solutions Japan Co., Ltd.

Technical & Sales Office

Shinbashi, Minatoku, Tokyo
Phone: +81-3-6452-9555
Fax: +81-3-6452-9557
Email: japan@gtisoln.com

Singapore: GTI Solutions Pte Ltd.

Technical & Sales Office

Selegie Road, Singapore
Phone: +65-3138-1769
Email: singapore@gtisoln.com



GTI SOLUTIONS
www.gtisoln.com

